

F3** Light Kit

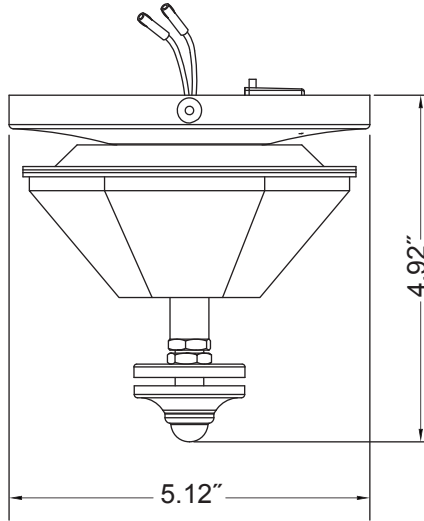

Available Finishes	
BN	Brushed Nickel
DZ	Dark Bronze
MW	Matte White

INSTALLATION REQUIREMENTS:

Remove the cover-switch and inner-switch housing from fan and install the light kit.

ELECTRICAL REQUIREMENTS:

Requires a grounded electrical supply line of 120 volts AC, 60 Hz, 15 amp circuit.

LIGHTING BULBS:

One 16-watt LED included.

CONTROL:

TR205 or BTT9R hand-held remote control are included in the motor assembly unit.

GLASS OPTIONS:

Uses glass bowls only. Optional G1 glass bowls— sold separately.

LOCATION USE:

Light kit is rated for dry and damp locations.

Light Bulb Information (120V)					
Bulb Type	Watts	QTY	Lumens Amount	Color Temp	CRI
LED	16	1	1250	3000	80%