

C2-220 Wall Control

SPECIFICATION and INSTRUCTION SHEET

DESCRIPTION: One Ceiling Fan & Light, 4 Speed-Rotary Control

ELECTRICAL SPECS: 220-240V, 50 Hz, Max.100W–Min.15W (Fan motor),
Max. 300W (Light), 3 Wire Installation

FAN MODELS USED: most 220-240V Fanimation fans



How to Wire and Operate Your C2-220 Wall Control

NOTE: If fan or supply wires are different colors than indicated, have this unit installed by a qualified electrician.

1. Installing Wall Control (Figures 1 & 2):

- With electrical power still disconnected, remove the existing wall plate and switch.
- Make wiring connections to terminal block as shown in Figure 1.
 - One black/white wire from wall control unit to red/brown (hot supply).
 - One orange wire from wall control unit to orange (light).
 - One brown wire from wall control unit to brown wire leading to ceiling outlet box.
- Attach wall control unit to outlet box using the two 6-32 screws provided.
- Attach wall plate to the switch control front.
- Restore electrical power.

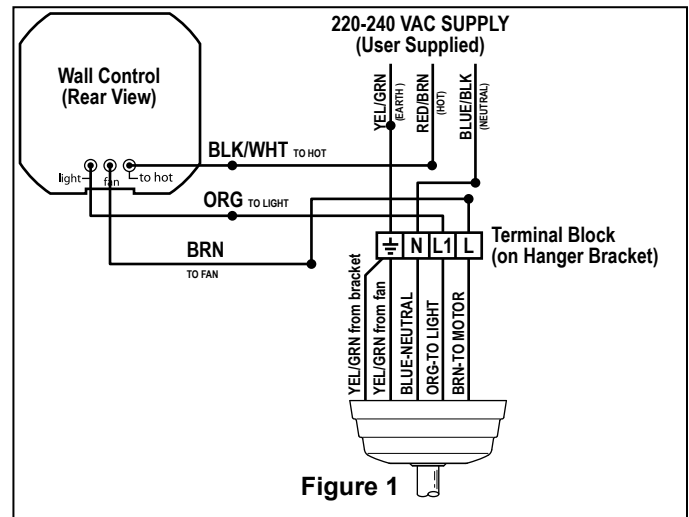

⚠ WARNING

To avoid possible fire or shock, make sure that the electrical wires are completely inside the outlet box and not pinched between the wall plate and the wall.

⚠ WARNING

Check to see that all connections are tight, including ground, and that no bare wire is visible at the wire connectors, except for the ground wire. Do not operate fan until the blades are in place. Noise and fan damage could result.

2. Operating & Using Wall Control:

NOTE: Set pull chain to high speed before using the wall control. You can now use your speed control to select any of the 4-speeds plus OFF.

- 4th Position – low fan speed
 - 3rd Position – low medium fan speed
 - 2nd Position – medium fan speed
 - 1st Position – high fan speed
 - OFF Position – fan off
- Light Control**
- Toggle Switch – on/off

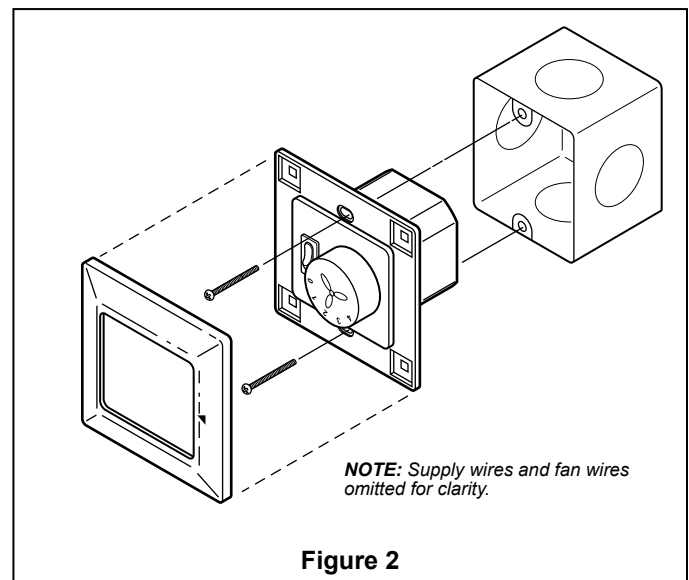

10983 Bennett Parkway
Zionsville, IN 46077
Toll Free (888) 567-2055
FAX (866) 482-5215
Outside U.S. call (317) 733-4113
Visit Our Website @ www.fanimation.com

Copyright 2008 Fanimation
2008/05